



SUN WEST ENGINEERING, INC.[®]

3802 E. BROADWAY Rd. PHOENIX, AZ 85040

PHONE: (602) 275-0662

FAX: (602) 276-2113

MAIL@SUNWESTENG.COM

19" Equipment Rack Shelf

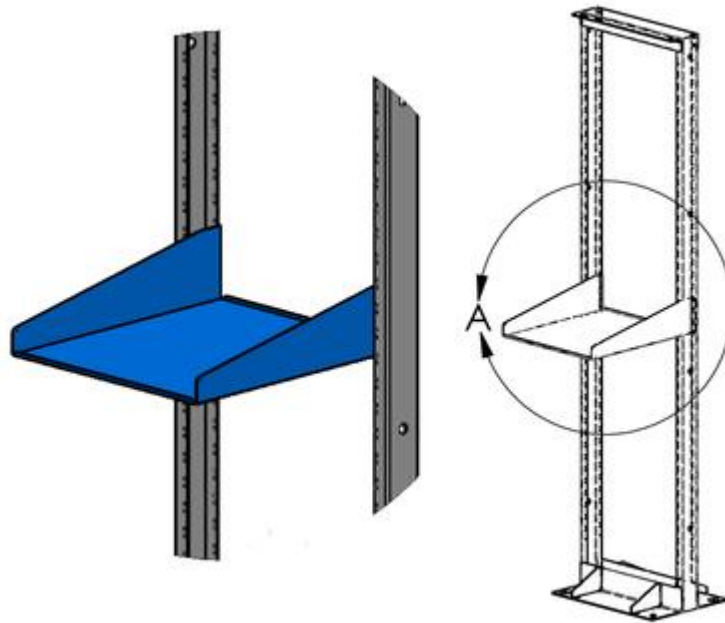

Put a shelf where you need it with Sun West's 19" equipment rack shelf.

Features Include:

- EIA 1-1/4" – 1/2" hole pattern & IBM 5/8"- 5/8" 1/2" Hole pattern
- Consumes 5 RU
- 2-Stage Catalyzed Epoxy Paint
- ANSI 61 Gray Finish

Please refer to the attached drawings and full specifications. Please consult factory for special configuration options.

**** PROPRIETARY AND CONFIDENTIAL ****
Copyright © 2015 Sun West Engineering, Inc.

**PROPRIETARY
PROPOSAL**

THIS PROPOSAL CONTAINS TRADE SECRETS AND OTHER PROPRIETARY AND CONFIDENTIAL INFORMATION OF SUN WEST ENGINEERING, INC.

THIS DOCUMENT AND ITS CONTENTS, INCLUDING WITHOUT LIMITATION THE DRAWINGS AND OTHER INFORMATION HEREIN, ARE THE SOLE AND EXCLUSIVE PROPERTY OF SUN WEST ENGINEERING, INC.

ANY DUPLICATION, DISCLOSURE, OR USE OF ANY PORTION OF THIS DOCUMENT REQUIRES THE PRIOR WRITTEN CONSENT OF SUN WEST ENGINEERING, INC.

VIOLATIONS OF THESE TERMS SHALL BE PROSECUTED TO THE FULLEST EXTENT OF THE LAW.

NAME: 19" Rack Shelf
DWG: S074103

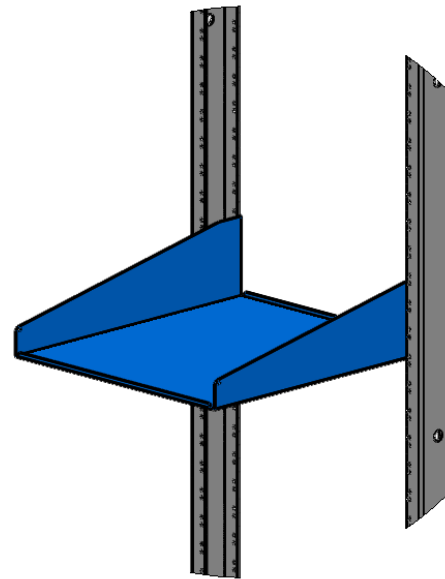
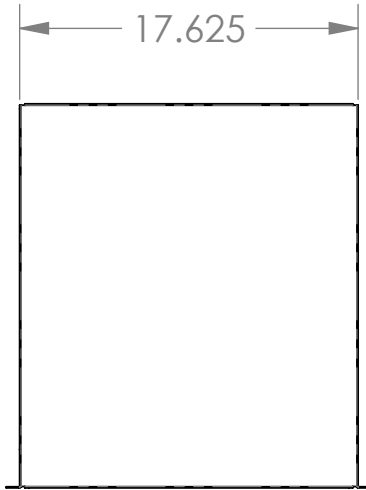
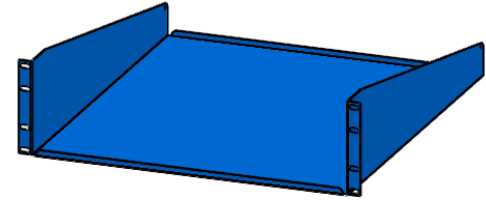

DETAIL A
SCALE 1 : 12

