

Utility CABINETS



CONSTRUCTION

- Cabinets Are Constructed From Galvannealed Steel With Epoxy Overcoats As Required Per Customer Specifications.
- All hardware is Stainless Steel or Grade-8 with Yellow Zinc Finish

SPECIFICATIONS

- Cabinets Are Constructed Per Western Underground Guide 2.13
- IEEE Power Engineering Society Standards C56.12.8 For Pad Mounted Equipment
- ANSI (American National Standards Institute) Standards For Outdoor Use
- NEMA (National Electrical Manufacturers Association) 3R Standards For Outdoor Use
- Available in Two Sizes:
 - SW-1976 42" x 42" x 51"
 - SW-1979 54" x 54" x 71"

**** PROPRIETARY AND CONFIDENTIAL ****
Copyright © 2014 and Present Sun West Engineering, Inc.

THIS PROPOSAL CONTAINS TRADE SECRETS AND OTHER PROPRIETARY AND CONFIDENTIAL INFORMATION OF SUN WEST ENGINEERING, INC.

THIS DOCUMENT AND ITS CONTENTS, INCLUDING WITHOUT LIMITATION THE DRAWINGS AND OTHER INFORMATION HEREIN, ARE THE SOLE AND EXCLUSIVE PROPERTY OF SUN WEST ENGINEERING, INC.

ANY DUPLICATION, DISCLOSURE, OR USE OF ANY PORTION OF THIS DOCUMENT REQUIRES THE PRIOR WRITTEN CONSENT OF SUN WEST ENGINEERING, INC.



SW-1976

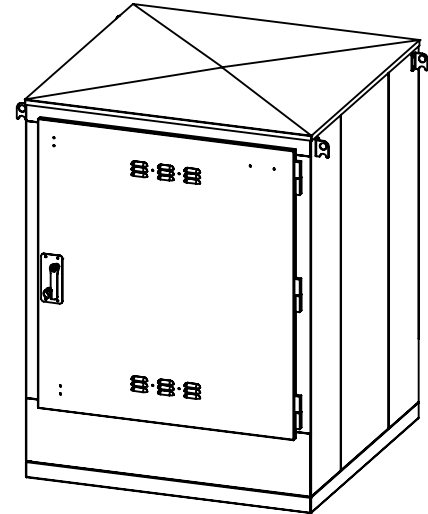
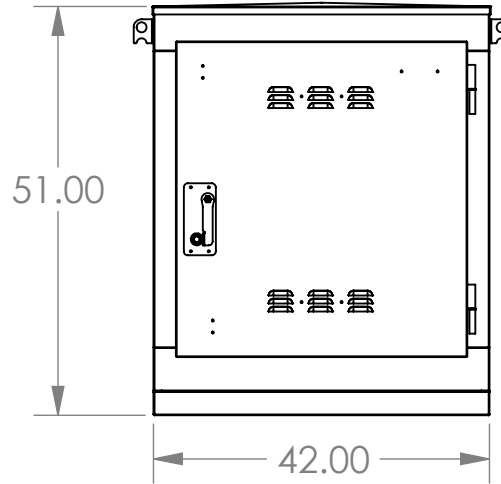
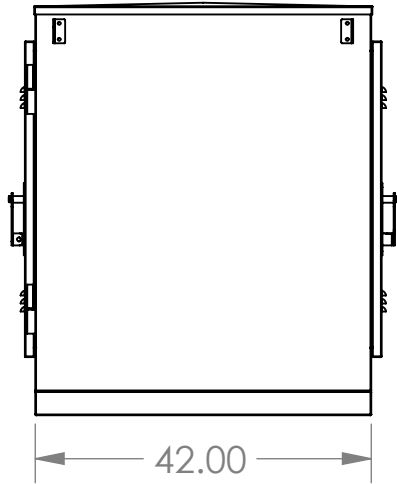

SW-1979

